



STUDY BUDDY™

Fourscore and Seven Years Ago

A ONE-ACT CIVIL WAR MUSICAL

Written by

Greg Gunning and Kathleen Huber

Music and Lyrics by

John Forster

WHAT HAPPENS IN
OUR PLAY?

Page 2

THE SETTING

Page 3

THE GETTYSBURG
ADDRESS

Page 4

WAR: A CONFLICT
OF IDEAS

Page 5

WRITERS CREATE
ATMOSPHERE

Page 6

THEATER
CONVENTIONS

Page 7

AFTER THE
PERFORMANCE

Page 8

RESOURCES

Page 8

**ARTSPOWER NATIONAL
TOURING THEATRE**

GARY W. BLACKMAN & MARK A. BLACKMAN
Executive Producers

Fourscore and Seven Years Ago

Written by Greg Gunning
and Kathleen Huber

Music and Lyrics by John Forster

Sets by George Allison

Costumes by Judy Kahn

Study Buddy Writer: Rosalind M. Flynn

Graphic Designer: Howard Levine

Editor: Andrea Skerratt

ARTSPOWER 39 South Fullerton Avenue, Montclair, NJ 07042-3354 973-744-0909

PLEASE PHOTOCOPY ANY OR
ALL OF THE FOLLOWING PAGES
TO DISTRIBUTE TO STUDENTS.

What Happens in *Fourscore and Seven Years Ago?*

In *GETTYSBURG*, in the summer of 1863, a young black man named *LEMUEL* works in a store owned by a Quaker widow, *MRS. McILHENY*. Lemuel recently escaped from slavery. Mrs. McIlheny employs him and teaches him to read. What Lemuel wants most, however, is to be a Union soldier and fight for *ABOLITION*. He has been told that black men are not permitted to join the army.

Officers from the Union (*SERGEANT HITCHBORNE*) and the Confederacy (*GENERAL PICKETT*) come to Mrs. McIlheny's store to obtain supplies. Both armies are preparing for a battle at Gettysburg. Lemuel meets *JACOB*, a young Confederate soldier who is Mrs. McIlheny's nephew. Jacob is rude and *CONDESCENDING* to Lemuel. He calls him "*BOY*" and orders him around. However, they soon discover that they have more in common than the difference in their skin color would have had them believe.

Lemuel and Mrs. McIlheny witness the *BATTLE OF GETTYSBURG*. They describe the *REGIMENTS* of soldiers in blue and gray uniforms, the *ARTILLERY*, the cannon fire, the *DRUMMERS*, and the dead and wounded.

Jacob is among the wounded. Although they risk charges of *TREASON*, Lemuel and Mrs. McIlheny help Jacob. Months later, recalling the words of President Abraham Lincoln's *GETTYSBURG ADDRESS*, they reflect on people who fight for their beliefs.

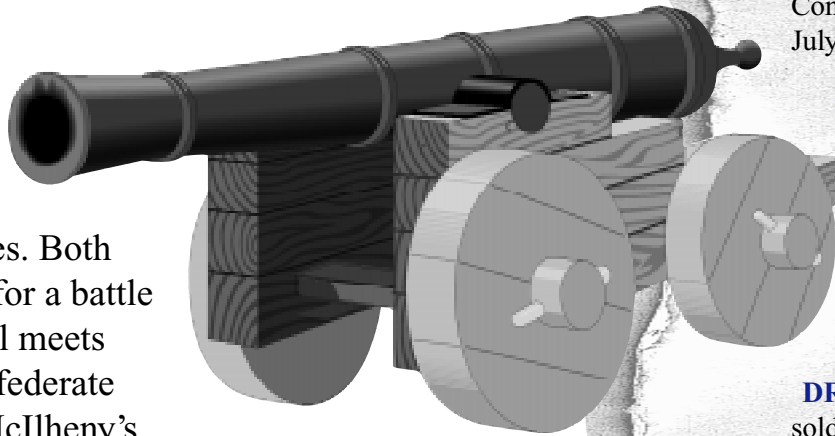

ABOLITION

a movement to rid the United States of slavery

CONDESCENDING

having a superior attitude

"BOY"

an insulting term for a black male, usually suggests servant or slave status

BATTLE OF GETTYSBURG

a Civil War battle fought between Union and Confederate forces on July 1-3, 1863

REGIMENTS

military units of ground troops

ARTILLERY

large guns and cannons

DRUMMERS

soldiers who beat rhythms on drums to send orders and inspire the soldiers

TREASON

the crime of betraying one's own country by purposely acting to aid its enemies

GETTYSBURG ADDRESS

famous speech written and given by President Lincoln at the dedication of the Gettysburg National Cemetery in November 1863. It begins, "Fourscore and seven years ago..."

The Setting of Our Play

The setting of *Fourscore and Seven Years Ago* is Gettysburg, Pennsylvania. The play's action occurs before, during, and after the famous battle.

Fourscore and Seven Years Ago features five characters created to tell the story and to represent historically significant groups of people involved in the U.S. Civil War.

DEFINITIONS:

FREE STATE—one of the United States in which owning slaves was illegal

DRY GOODS—textiles, clothing, and other related items

UNDERGROUND RAILROAD—a series of safe hiding places created to help escaping slaves reach “free states”

QUAKER—a Christian religion also known as the Society of Friends.

CONFEDERATE—referring to the association of southern states that withdrew from the United States in 1860 to govern themselves

UNION—the northern states that remained loyal to the existing U.S. government

Characters

LEMUEL is a young black man. He works in a dry goods store in Gettysburg in the *free state* of Pennsylvania.

MRS. MCILHENY is a Quaker widow who owns the *dry goods* store. She employs Lemuel and teaches him how to read.

JACOB is a young *Confederate* soldier who is also Mrs. McIlheny's nephew.

SERGEANT HITCHBORNE is an officer in the *Union* army.

GENERAL PICKETT is a commander of *Confederate* troops.

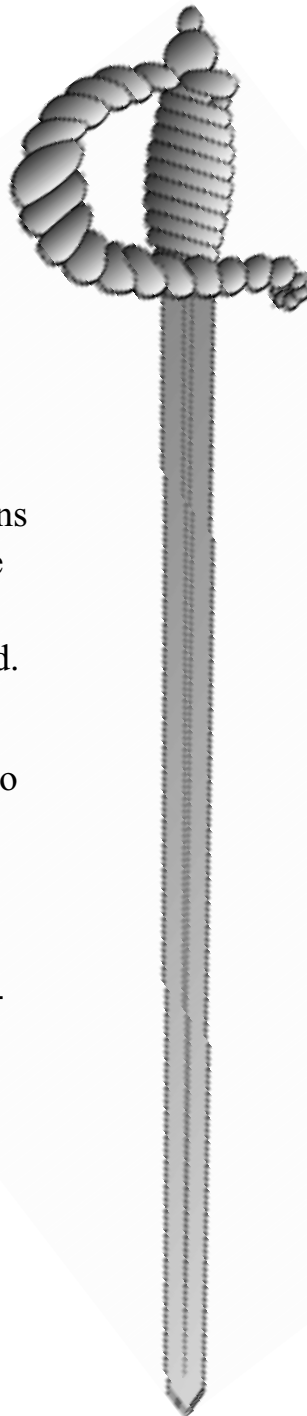

Historical Significance

LEMUEL represents those black people who *escaped slavery* via the *Underground Railroad*.

MRS. MCILHENY represents people of the *Quaker religion* who do not believe in war or slavery.

JACOB represents the *inexperienced and untrained youths* who joined the Civil War armies of the North and the South. His relationship with his aunt illustrates that in civil wars, members of the same family often fight on opposing sides.

SERGEANT HITCHBORNE represents the officers of the forces of the North. His activities illustrate that not all people on the “winning” side are honest and principled.

The real **GENERAL GEORGE PICKETT** led 15,000 Confederate soldiers at Gettysburg in the bloodiest attack of the Civil War.

The Gettysburg Address

Fourscore and Seven Years Ago takes its title from the first sentence of President Abraham Lincoln's Gettysburg Address.

In 1863, the United States was in the middle of a *CIVIL WAR*. (A *CIVIL WAR* is a war fought between two groups of people that live in the same country.) On July 1-3, 1863, on an open field beside the small town of Gettysburg, Pennsylvania, Union forces from the northern United States fought a long and bloody battle against troops from the southern Confederate States of America.

After the battle, President Lincoln wrote and delivered a speech at the dedication of the Gettysburg National Cemetery. That speech has become one of the most famous in American history. It is called the *GETTYSBURG ADDRESS*.

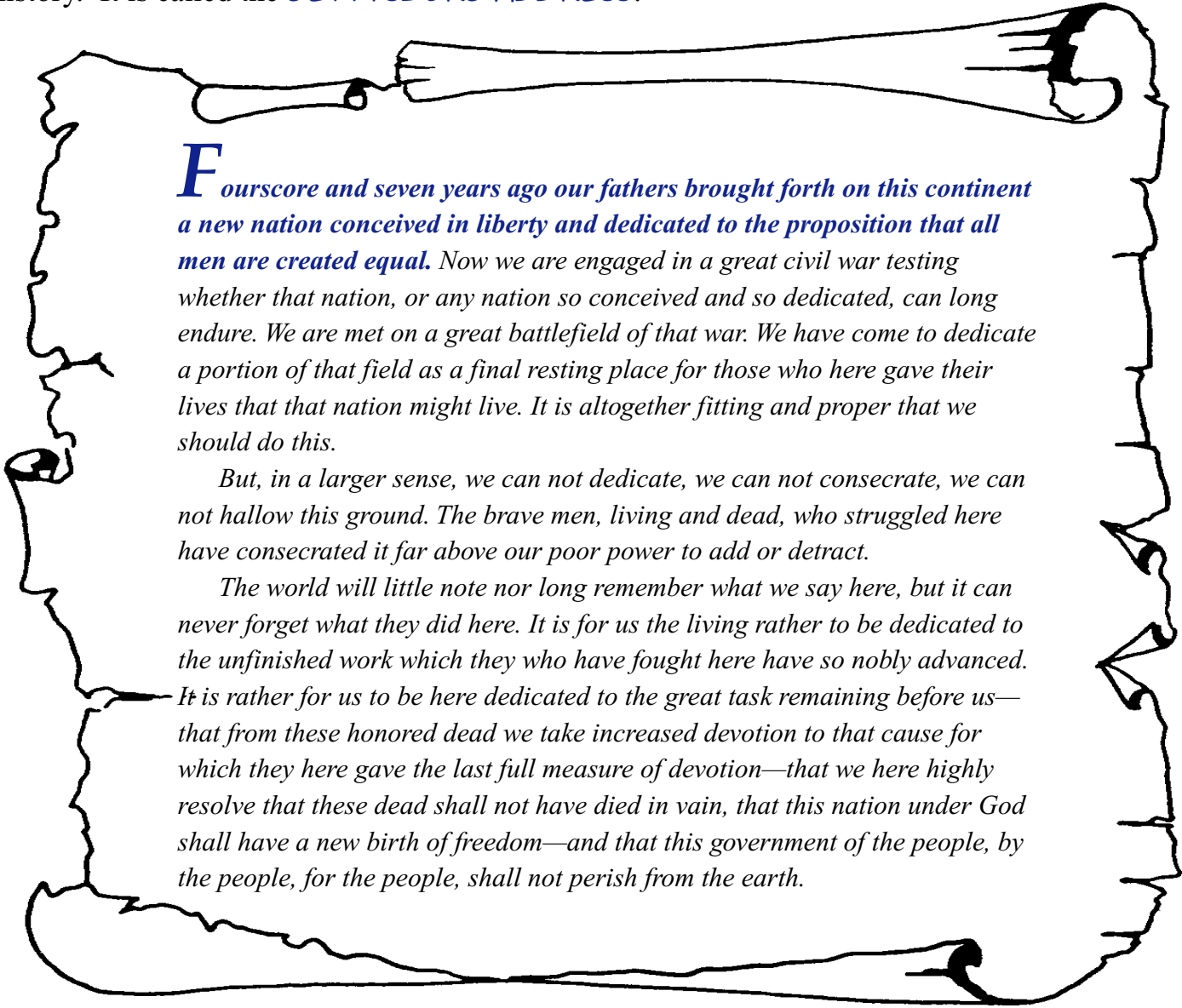

Fourscore and seven years ago our fathers brought forth on this continent a new nation conceived in liberty and dedicated to the proposition that all men are created equal. Now we are engaged in a great civil war testing whether that nation, or any nation so conceived and so dedicated, can long endure. We are met on a great battlefield of that war. We have come to dedicate a portion of that field as a final resting place for those who here gave their lives that that nation might live. It is altogether fitting and proper that we should do this.

But, in a larger sense, we can not dedicate, we can not consecrate, we can not hallow this ground. The brave men, living and dead, who struggled here have consecrated it far above our poor power to add or detract.

The world will little note nor long remember what we say here, but it can never forget what they did here. It is for us the living rather to be dedicated to the unfinished work which they who have fought here have so nobly advanced. It is rather for us to be here dedicated to the great task remaining before us—that from these honored dead we take increased devotion to that cause for which they here gave the last full measure of devotion—that we here highly resolve that these dead shall not have died in vain, that this nation under God shall have a new birth of freedom—and that this government of the people, by the people, for the people, shall not perish from the earth.

War: A Conflict of Ideas

In the play *Fourscore and Seven Years Ago*, the playwrights were very careful to represent many different views of what was happening in the Civil War.

THE UNION

(also called *The North* and *The Yankees*)

The main government was fighting to retain the United States as one country with one central government that could make laws for the whole country.

Many people were also fighting to abolish slavery in the whole country, not just in certain states.

PACIFISTS

People who hate all kinds of fighting or whose religions forbid fighting are called “pacifists” (*pass-i-fists*). During the Civil War, pacifists felt both sides were wrong, and that the way to solve differences was through talking, or “negotiation.”

THE CONFEDERACY

(also called *The South* and *Dixie*)

The main government was fighting to support the right of individual states to choose which laws worked best for those states and to oppose the right of a central government to impose laws on the whole country.

Many people were fighting to keep slavery, even though they knew it was morally wrong. They knew that without slaves, the large farms of cotton and tobacco would fail; the farmers didn’t make enough money to pay as many workers as they needed. Without slaves, the farms would fail and the whole south would be an economic disaster.

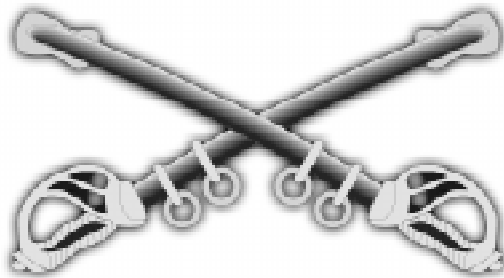

STUDENT ACTIVITY:

Imagine that you are on a news panel in 1862. This quote, taken from a song in the play, is your topic of conversation.

A war like this is terrible.

But one thought makes it bearable:

“Our cause is just and cannot be denied.

How can you lose with God on your side?

Writers Create Atmosphere

PLAYWRIGHTS are people who write plays. They tell stories through lines written for actors to speak. Those lines need to keep the actions of the story moving, show the character of the person who is speaking, and give an idea of the time in which the story takes place.

LYRICISTS write the words for the songs. These songs need to reflect the moods of the characters and help to underline important conflicts and discoveries. ArtsPower's playwright and lyricist used many sources to help them get the **ATMOSPHERE** (the general feeling) for this play. They researched the mid-1800s so they could use the correct words for things and get the atmosphere of the play right.

This advertisement appeared in a newspaper named *The Gettysburg Compiler* in June 1863. It inspired the playwrights to create the character of Mrs. McIlheny and to use the dry goods store as a setting in the play.

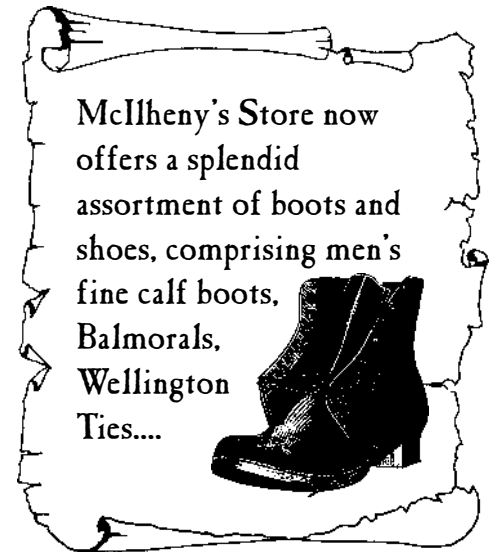

Quakers:

"Thee" instead of "You"

The character Mrs. McIlheny is a Quaker. Until the late 1800s, Quakers spoke "plain speech." They felt that "thee" was less formal than "you." They used "thee" to address every person because they believed in equality among all human beings. *During the performance, listen for "thee" in Mrs. McIlheny's lines, as in: "Friend Blackwell, thee knows we sell no weapons."*

Sergeant Hitchborne tells Mrs. McIlheny that she might get six dollars for her three-dollar blankets on the **BLACK MARKET**. Mrs. McIlheny rejects war profiteering, underlining her character's strong morals.

A **BLACK MARKET** is an illegal way to sell goods. A **WAR PROFITEER** makes large amounts of money (profits) during wartime by selling items that are in short supply.

Yanks • Rebs • Dixie

YANKEES or **YANKS** was the nickname for Union soldiers in the Civil War. Confederate soldiers were called **REBS** because they were **REBELS** against the United States. **DIXIE** was the nickname for the states that were south of the **MASON-DIXON LINE**, an old boundary line that served to separate the free states from the slave states.



Theatre Conventions

When you attend a play, you agree to pretend. You agree to “suspend disbelief” and pretend that the stage, the action, and the characters are all real. To present a story on stage, actors and other theater artists often rely on *THEATER CONVENTIONS*. These conventions are accepted ways of acting to tell the story. The playwrights know that in the real world, people would not behave this way.

THE PLAY IS A MUSICAL. Characters sing songs that tell stories and reveal their inner thoughts.

CHARACTERS FREEZE IN POSITIONS ON STAGE. Even though the audience can still see them, “frozen” characters are not part of the action on stage.

CHARACTERS SPEAK THEIR THOUGHTS OUT LOUD. The character of Lemuel also speaks directly to the audience. In this way, he is sometimes a narrator who provides background information and comments on characters and events.

THE STAGE IS “SPLIT.” Two sides of the stage are used to show different things happening at the same time.

SOME ACTORS PLAY MORE THAN ONE CHARACTER. In theater, this is called “doubling.”

ACTORS MOVE IN SLOW MOTION. This is a way to show speed and confusion.

TIME IS COMPRESSED. Days, weeks, even years can go by on stage simply by ending one scene and starting another.

After the Performance

Discussion Questions

Which parts of the play were fact? Which parts were fiction?

How does the play show what might have happened?

Does the playwright of this play show an opinion?

Are we supposed to feel that one character is “right” in his political beliefs?

Activities

Write a letter to ArtsPower letting them know

your reactions to *Fourscore and Seven Years Ago*.

Use the following questions to stimulate your thoughts:

What did you like or dislike about the performance?

How did the performance effect you?

Which actors did you believe? Why?

Send your letters to:

ArtsPower National Touring Theatre

39 South Fullerton Avenue

Montclair, New Jersey 07042-3354

or e-mail us at www.artspower.org and click on “Contact Us”.

Resources:

Print:

Lincoln, Abraham. The Gettysburg Address. NY: Houghton Mifflin, 1995. Lincoln’s text is illustrated by Michael McCurdy in this picture book.

Murphy, Jim. The Long Road to Gettysburg. NY: Clarion Books, 1992. This book, which provides firsthand accounts of the battle of Gettysburg, includes numerous photographs, maps, and drawings.

Video:

Gettysburg. Directed by Ronald F. Maxwell. Atlanta: Turner Home Entertainment, 1994.

Web:

www.gettysburg.com/bog/bogstory/story1.htm

